



International Journal Of Engineering Sciences & Management Research

SMART PHONE BASED HOUSEHOLD MANAGEMENT SYSTEM USING ARM PROCESSOR

***T.Deepa, B.Harini**

*Department of EEE, SVS College of Engineering, Coimbatore, Tamilnadu, India

Department of EEE, SVS College of Engineering, Coimbatore, Tamilnadu, India

KEYWORDS: Home Automation, Security System, GSM modem, Wireless Technologies.

ABSTRACT

The project aim is to design a highly secured multi-way home automation system that allows the user to control all the electric and electronic devices by any android smart phone using voice recognition technology. Not only that, the system also allows the user to control the home devices using SMS commands from any GSM phone. When the user is out of home, she/he could simply send the same command using SMS from any GSM phone. A fire sensor monitors the temperature of the home constantly and if it goes beyond a certain limit, the system would interpret this as fire occurred and alerts the place using alarm buzzer and send message to the user's mobile phone as well as to the fire station. If the system detects any forceful entry such as a window smash action the system immediately triggers relay and sends SMS to the user's mobile phone. Garden Motor can be turned ON or OFF using either voice or SMS depending on the user location. If we are out of town, a small motor mechanism is used to feed the pet..

INTRODUCTION

Intelligent home appliance control system makes use of modern computer and cellular technologies to control home appliances in a faster, cheaper and in an energy efficient way. This work presents a home appliance control system which is developed through ARM processor, wireless communication technology. In this system, user can control appliances through a hand held mobile terminal. Intelligent home appliance control system is developed through ARM microprocessor, embedded C, wireless communication technology. Wireless communication technologies are becoming more popular around the world and the consumers appreciate this wireless lifestyle which gives them relieve of the well-known wiring [4]. Now with the wireless technology digital devices form a network in which the appliances and devices can communicate with each other.

The rapid growth of wireless communication motivated us to use mobile phones to remotely control household appliances such as light, fan and motor for garden maintenance. Two modes of control according to the user location, Bluetooth for Indoor and GSM for Outdoor. Different sensors are used to sense fire and window break, it will detect and giving alert messages to our mobile phones. When out of town, the user need not worry about feeding their pet animal. Simply send an SMS from their mobile phone and the system has servomotor to feed the pre stored food to the plate. The system allows one unique mobile phone to control all the home devices. The system is portable and constructed in a way that is easy to install, configure, run, and maintain.

A typical wireless home automation system allows one to control house hold appliances from a centralized control unit which is wireless. The project demonstrates a system that can be integrated as a single portable unit and allows one to wirelessly control lights, fans and turn on or off appliance that is plugged into a wall outlet, get the status of sensors and take decision accordingly. The microcontroller would then control and device based on the information given to it.

Home Safety is one of the most important requirements for people. With the development of network and automatic control technology, a remote home security monitoring and alarming system becomes more and more practicable today. GSM technology, we can design a remote home security monitoring and alarming system that can detect the theft, fire etc and send alarm message to the house owner's mobile phone [1]. By combining sensors and wireless communication, wireless technology can detect, collect and deal with the object information in its covering area, and send data to the observer.

GENERAL ARCHITECTURE

A highly secured multi-way home automation system allows the user to control all the electric and electronic devices from any android Smartphone. The system allows the user to control the light and fan using SMS commands from any GSM phone. Fire alert and window break alert SMS sends to the user's mobile phone. To feed the pet from pre stored food and maintenance of garden using motor. Intelligent home appliance control

system is developed through ARM microprocessor, embedded C, wireless communication technology. Simulation for the proposed system is done in Proteus software.

The system allows the user to turn the light, fan and other home appliance ON or OFF using a voice command from his android Smartphone if the user is available within home. When the user is out of home, he could simply send the same command using SMS from any GSM phone. A fire sensor monitor the temperature of the home and if it crosses a certain threshold, the system would interpret this as fire occurred and alerts the place using alarm buzzer and send SMS to the user mobile phone as well as to the fire station. Vibration sensor is used to monitor window movements and if it detects a forceful entry such as a window smash action the system immediately triggers alarm buzzer and sends SMS to the user phone.

Garden Motor can be turned ON or OFF using either voice or SMS depending on the user location. If the person is out of town, a small servo motor mechanism is used to feed the pet that would automatically rotate and pushes the pre stored food item on the plate below. The servo then returns back to its original position. the system Relay driver is connected to the ARM and relays are connected to the relay driver.

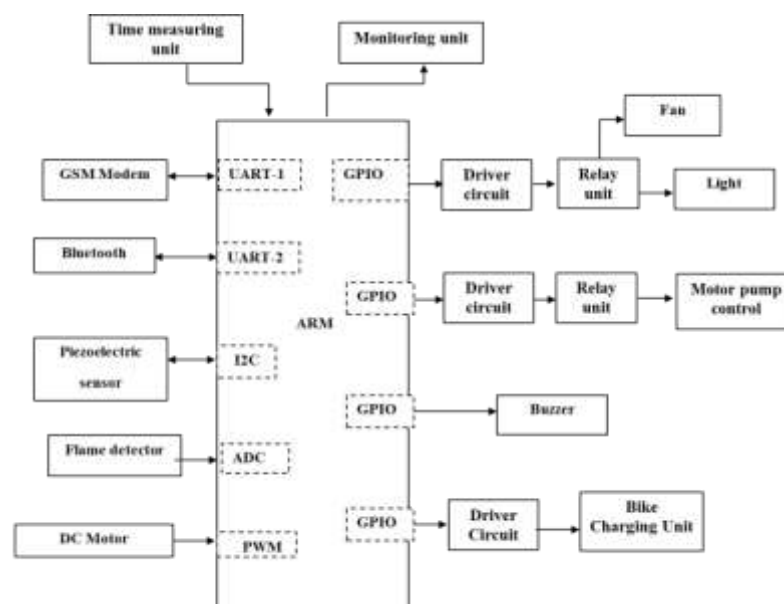

Fig 1- Block diagram of the system

As shown in Fig 1 different appliances are connected to the relays. ARM processor receives signals from the transmitter through the GSM. The signal conditioning unit is constructed with operational amplifier which acts as comparator. It received the signal from all above mentioned transducer and generates the square pulse. Then this square pulse is given to microcontroller. Here the microcontroller is flash type reprogrammable microcontroller in which it have already programmed with desired phone number.

Current transformer is used for measuring the current units per day for daily uses. Here we are implementing one new concept Time measuring concept. This concept is user to check current usage for every one hour or user when will they need to check and take log. Bike charging unit is electric rechargeable bike need power source for charging purpose. After charged the vehicle some power losses are occurring. Overcome of power loss is after complete the charge to cut off the power supply for bike charging unit. Here all type of home appliances are control by ARM Processor and wireless sensor networks. In this work a low cost, secure, remotely as well as closely controlled solution for automation of homes has been designed. This design is novel and has achieved the target of controlling home appliances through wireless communication technology and schedule power technology.

This project is an example of embedded system and mobile communication as all its operations are controlled by intelligent software inside the microcontroller and communication takes place using a cell-phone. Here is a circuit that lets operate the home appliances like lights and water pump from the office or any other remote place [9]. So

if anyone forgets to switch off the lights or other appliances while going out, it help him to turn off the appliance with his cell-phone.

SYSTEM OVERVIEW

The overview of hardware components used in the proposed system is described as follows.

SENSOR UNITS

A piezoelectric sensor is a device that uses the piezoelectric effect to measure pressure, acceleration, strain or force by converting them to an electrical signal. Piezoelectricity is the ability of crystals and certain ceramic materials to generate a voltage in response to applied mechanical stress. Piezoelectricity was discovered by Pierre Curie and the word is derived from the Greek piezo in, which means to squeeze or press. As shown in Fig 2, Piezo electric plate is the special type of sensor which is used to sense the mechanical vibration. Piezo electric plate converts the mechanical vibration to electrical signal. The converted electrical signal is in the range of small milli voltage signal.

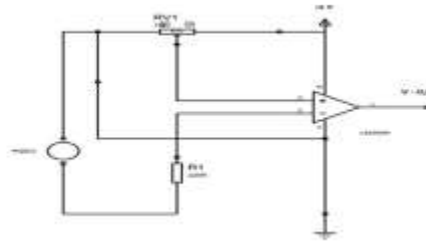

Fig 2- Vibration Sensor

The flame sensor monitors the burner section of the furnace, whether it's gas or oil, to determine if there is a flame present during the ON and OFF cycle. This circuit works on the principle of flame rectification. If the flame is not detected during the trial for ignition, the IFC will stop the gas flow or oil flow to the burner. The flame detection on a gas furnace consists of a flame sensing rod connected to Integrated Furnace Control (IFC). The IFC places an AC (Alternate Current) potential of anywhere from 60 to 100 volts in the wire connected to the flame sensing rod. The flame sensing rod is positioned in front of the burner in a Direct Ignition system. When the ignition source lights the burner, the sensing rod is in the path of the flame. When air and fuel are burned ionization occurs, these ions have the ability to conduct electricity, an extremely weak conductor but a conductor none the less.

MOTOR DRIVER

A DC motor is an AC synchronous electric motor that from a modelling perspective looks very similar to a DC motor. Motor driver circuit using the L293D motor driver. A motor driver always has a battery input Vs.

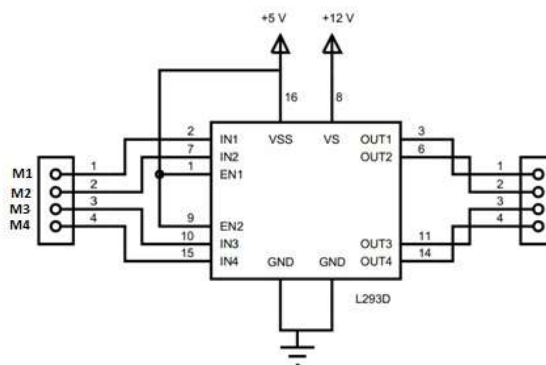

Fig 3 - Pet Feeding Mechanism

Simple terms, what a motor driver does is that it directs the V_s voltage to the motors connected to it. Thus, the motors behave as per the control signals generated using the MCU with the excitation from the external battery voltage. L293D is a 16 pin IC which comes in a DIP (Dual in Package) shown in Fig 3. A relay is an electrical switch that opens and closes under the control of another electrical circuit. In the original form, the switch is operated by an electromagnet to open or close one or many sets of contacts. Because a relay is able to control an output circuit of higher power than the input circuit, it forms of an electrical amplifier.

When a current flows through the coil, the resulting magnetic field attracts an armature that is mechanically linked to a moving contact. The movement either makes or breaks a connection with a fixed contact. When the current to the coil is switched off, the armature is returned by a force approximately half as strong as the magnetic force to its relaxed position. Usually this is a spring, but gravity is also used commonly in industrial motor starters. Most relays are manufactured to operate quickly. In a low voltage application, this is to reduce noise. In a high voltage or high current application, this is to reduce arcing.

If the coil is energized with DC, a diode is frequently installed across the coil, to dissipate the energy from the collapsing magnetic field at deactivation, which would otherwise generate a spike of voltage and might cause damage to circuit components. Some automotive relays already include that diode inside the relay case. Alternatively a contact protection network, consisting of a capacitor and resistor in series, may absorb the surge. If the coil is designed to be energized with AC, a small copper ring can be crimped to the end of the solenoid. This "shading ring" creates a small out-of-phase current, which increases the minimum pull on the armature during the AC cycle.

CURRENT MEASUREMENT

The current measurement circuit is designed in Fig 4, to monitor the supply current. The supply current that has to monitor is step down by the current transformer. The step down current is converted by the voltage with the help of shunt resistor. Then the converted voltage is rectified by the precision rectifier. The precision rectifier is a configuration obtained with an operational amplifier in order to have a circuit behaving like an ideal diode or rectifier.

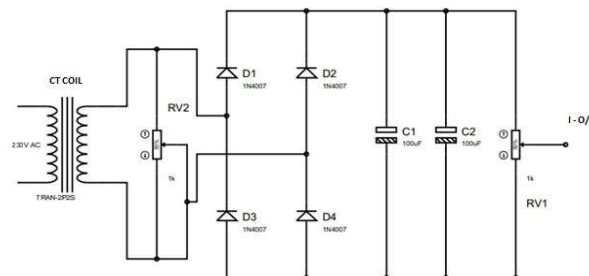

Fig 4- Current Measurement Circuit

Liquid crystal displays (LCD's) have materials, which combine the properties of both liquids and crystals. Rather than having a melting point, they have a temperature range within which the molecules are almost as mobile as they would be in a liquid, but are grouped together in an ordered form similar to a crystal. An LCD consists of two glass panels, with the liquid crystal material sandwiched in between them. The inner surface of the glass plates are coated with transparent electrodes which define the character, symbols or patterns to be displayed. Polymeric layers are present in between the electrodes and the liquid crystal, which makes the liquid crystal molecules to maintain a defined orientation angle. A battery is a device that stores energy. The way that it stores energy is by holding different electro-chemically active materials together in such a fashion so that they can generate and store free electrons for long periods of time and only deliver that energy when the battery user demands it.

WORKING OF GSM MODEM

The GSM modem acts like a cellular phone and transmits text and voice data. It communicates with the GSM network via the SIM card. The Global System for Mobile Communications is the most popular standard for mobile phones in the world. GSM service is used by over 2 billion people across more than 212 countries and territories [10]. The ubiquity of the GSM standard makes international roaming very common between mobile phone operators, enabling subscribers to use their phones in many parts of the world. GSM differs significantly

from its predecessors in that both signal and speech channels are Digital call quality, which means that it is considered a second generation (2G) mobile phone system. This fact has also meant that data communication was built into the system from the 3rd Generation Partnership Project (3GPP). When any object is detected by piezoelectric sensor then it sends the command to the microcontroller and now microcontroller send the command to the GSM module. GSM module have a SIM card, with the help of SIM card GSM module send the SMS on give mobile number which is already programmed in the microcontroller.

SOFTWARE DESCRIPTION

Proteus (PROcessor for Text Easy to USE) is a fully functional, procedural programming language created in 1998 by Simone Zanella. It is especially versatile in dealing with strings, having hundreds of dedicated functions this makes it one of the richest languages for text manipulation. Proteus was designed to be practical (easy to use, efficient, complete), readable and consistent. Proteus includes hundreds of functions for accessing file system, sorting data, manipulating dates and strings, interacting with the user (console functions), Calculating logical and mathematical expressions. Running a Proteus script as a service, started as soon as the operating system has finished loading, gives many advantages, no user needs to login to start the script, A service can be run with different privileges so that it cannot be stopped by a user. This is very useful to protect critical processes in industrial environments (data collection, device monitoring), or to avoid that the operator inadvertently closes a utility (keyboard emulation).

The proposed system characteristics involve remote controlling of appliances, intrusion detection, system security and auto-configuration such that system automatically adjusts the system settings on running hardware. The system has useful features such as displaying of battery level, charging status and signal strength of the mobile thus making system reliable. This system has many advantages such as remote controlling of home appliances, availability and ease of users. The user can get alerts anywhere through the GSM technology thus making the system location independent. The system contains low cost components easily available which cuts down the overall system cost. The ease of deployment is due to wireless mode of communication.

GSM technology provides the benefit that the system is accessible in remote areas as well. The system reliability increases due to the useful features such as battery level checking, charging status and signal strength indicating the system about threats [3]. The system integration is simple, scalable and extensible. However, the system functionality is based on GSM technology so the techno-logical constraints must be kept in mind.

IMPLEMENTATION AND DISCUSSION

Home security system is designed using LPC2148 microcontroller, GSM module is connected to UART0 peripheral of LPC2148 for wireless communication to system. Vibration and current sensor modules are connected with AD0.2 and AD0.3 for measuring vibration and current. Alarm is connected with digital output pin of port1.26 and also scheduled motor, light; fan and battery are connected to port1.27, 28, 29, and 30 as digital out pins. Pet feeder mechanism driver circuit is connected with port0.16 – port0.19 using L293D motor driver.

User can control and schedule Home appliances remotely via GSM using Control Commands. Light, Fan, Motor and Battery Load can be Controlled and scheduled as by user needs. In Battery controlling mode user can switch ON the Battery and after full charge it can be off automatically by detecting standby power of any appliances. Standby power can be reduced by switching off appliances which are in standby results in reducing power consumption and saves electricity.

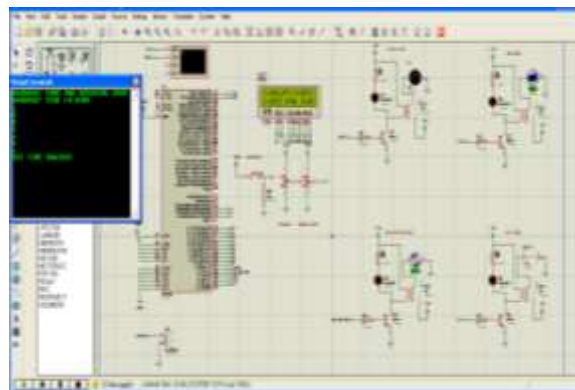

Fig 5- Simulation results in Proteus software



International Journal Of Engineering Sciences & Management Research

In home security system whenever fire occurs in home flame sensor detects the signal flame and provides signal to controller which informs user and fire service that fire in home. Then Vibration sensor detects breaking of window or door and alerts user about security information of home. Pet feeder can be controlled remotely for giving foods for pets at any time when we are off home. The circuit was build and tested. Fig 5 shows the simulation result for home appliances and setting time for motor run. It also shows the alert messages for temperature and fire control. A, B, C for Load ON and a, b, c for Load OFF. If temperature is $T > 30$ degree Alarm Beeps and sends alert message to the user's mobile phone and also to the nearer fire station. If vibration is $V > 500$ degree Alarm Beeps and sends alert message to the user's mobile phone. If number sends via hyper terminal it takes for scheduled motor load.

CONCLUSION

The theme of the design is to establish a Smart Home control system based on GSM short message, in order to control and monitor home devices and its environmental conditions. It has several advantages of convenient, fast, high efficiency. GSM technology capable solution has proved to be controlled remotely, provide home security and is cost-effective as compared to the previously existing systems. Hence it can be concluded that the required goals and objectives of project have been achieved. The system has been simulated using Proteus software. This project presents a mobile controlled and user- friendly approach to the available home automation system.

REFERENCES

- [1] Aayush Agarwal and R.C.Joshi (2012) 'WSN GSM based Remote Home security system' International Conference on Recent advances and Future Trends in Information technology (IRAFIT).
- [2] Ahmad.A.W and Jan. N (2011) 'Implementation of GSM-Zigbee based Home Security Monitoring and Remote Control System' IEEE International Midwest Symposium on Circuit and Systems, pp. 1-4.
- [3] Chutia.R and Sonowal.D (2011) 'Remote household appliance control system using GSM', International conference of advanced computing and communication technologies (ACCT).
- [4] Dinusha Rathnayaka.A.J (2011) 'Evaluation of Wireless Home Automation Technologies' International Conference on Digital Ecosystems and Technologies (IEEE DEST).
- [5] GaoMingming and Shao Liangshan (2010) 'The Design of Wireless Smart Home System based on ZigBee' International Conference on Computer and Electrical Engineering, Vol. 53.No.42.
- [6] Gill K. Shuang-Hua Yang and Xin Lu (2009) 'ZigBee based Home Automation system', Consumer Electronics, IEEE Transaction.
- [7] Huiping Huang and Shide Xiao (2011) 'A Remote Home Security System Based on Wireless Sensor Network and GSM Technology' International Conference on Networks Security Wireless Communications and Trusted Computing.
- [8] Inderpreet Kaur (2010) 'Microcontroller Based Home Automation System with Security' (IJACSA) International Journal of Advanced Computer Science and Applications.
- [9] Michal Varchola (2007) 'Zigbee Based Home Automation Wireless Sensor Network' Acta Electrotechnicaet Informatica, Vol. 7, No. 4.
- [10] Nelofar Tyagi and Ashish Joshi (2013) 'A Comparative Approach to Remote Home Security System Based on Wireless System Network and GSM' International Journal of Scientific & Engineering Research, Vol.4, Issue No.6.
- [11] Verma, G. K and Tripathi.P (2010) 'A Digital Security System with Door Lock System Using RFID Technology'